

New Output Option for 277/278 Series - "ZY" Output

Here's a new and innovative output option for the Chelsea 277/278 Series Powershift Power Take-Offs (P.T.O.) used on Allison and Caterpillar Transmissions.

The current 277/278 "XY" flange option for direct mount pumps with an 8-tooth (DIN 5462) spline mounting option requires a long P.T.O. flange mount and a special output shaft adapter to mount the pump. This mounting option sometimes creates pump interference with the transmission.

The NEW "ZY" output for the 277/278 Series is approximately 2.77" [7 cm] shorter in length from Center Line (CL) of the P.T.O. to Flange Face (FC). This will allow direct mounting of pumps such as the Parker F1 and VP1 Series.

Another innovative feature of the "ZY" option is that it comes standard as a wet spline output. With today's high engine torsional vibrations causing shorter P.T.O./Pump shaft spline life, the wet spline feature reduces fretting/corrosion and has shown to provide more than 10 times reduction in spline wear.

The NEW "ZY" option must be ordered from the factory, there is not a field conversion kit available for this option at this time. Kits available for this option are Driveshaft & Clutch Assembly, Gasket & Seal Kit, Bearing Kit, and Clutch Repair Kit. (See back of this bulletin for kit numbers)

277 "XY" Output

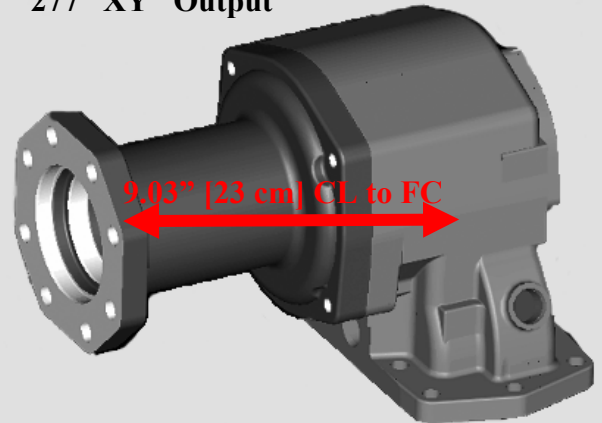

277 "ZY" Output

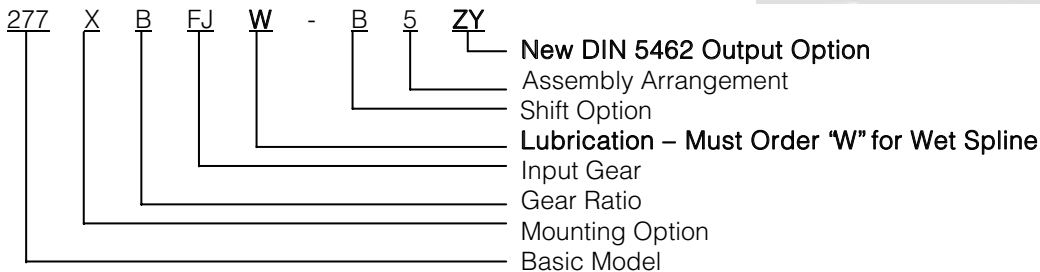
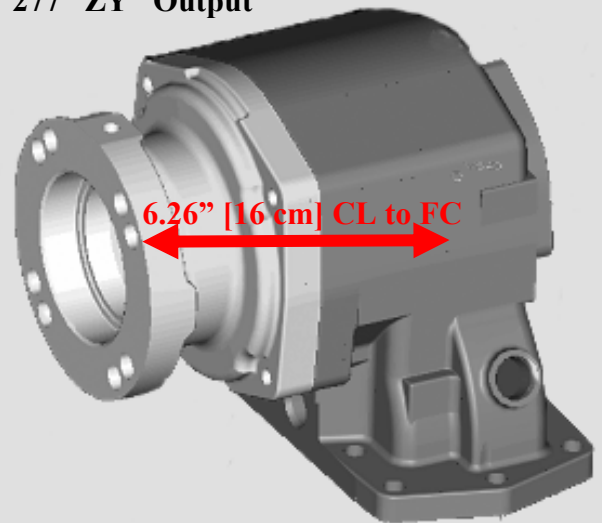

Kit Number	Description
329613X	Drive Shaft & Clutch Assembly
329071-43X	Kit – Gasket & Seal
329071-44X	Kit – Bearing
329071-45X	Kit – Clutch Repair

Recap of Features and Benefits

- **Reduced Flange length by 2.77”[7 cm]**
Reduces Pump to Transmission interference
- **Wet Spline Option Standard**
Wet Spline shafts have shown to provide more than 10 times reduction in spline wear depending on the application
- **8 Pump Flange Mounting Holes**
Provides for more Pump Mounting Options

If you have questions about this bulletin or other technical questions, contact us at:

US: Chelsea Customer Services at 662-895-1052
Canada: Parker Hannifin Canada, Motion & Controls Division 905-693-3020



Walt Harris
Product Sales Manager
Chelsea Products