

New "RK" Flange for 277/278 Series

Chelsea engineering has developed a new Rotatable Cast Iron flange for the 277/278 Series Power Take-Offs (P.T.O.s). This new design is a first for Chelsea and the work truck industry as you now have the option to specify a ROTATABLE WET SPLINE.

As Chelsea keeps pace with the increased torsional vibrations from low speed, high compression, higher torque engines, a major cause for the increase in pump shaft failures know as spline fretting, the new rotatable wet spline "RK" can be a real problem solver in reducing P.T.O./Pump shaft spline wear.

Some features of the wet spline option are:

- Wet Spline keeps P.T.O. and Pump Splines in a bath of oil at all times
- Virtually eliminates all material oxidation (fretting) since splined connections are cushioned with an oil film
- Wet spline standard in European Refuse for approximately 10 years and as an option in North America for 4 years
- Applications that have changed to Chelsea's wet spline include Refuse, Yard Spotter Tractors, Material Handling Trucks, RV Motor Coaches.



The new "RK" (Patent Pending) S.A.E. "B" 2 or 4 Bolt with a "B" Shaft (7/8" -13 Tooth) will replace the current "RA" and "RB" flange options on the 277/278 Series P.T.O.s.

This one flange option now gives you more flexibility in inventory management by replacing the "RA" (S.A.E. "B" 2-Bolt Flange w/ "B" Shaft 7/8"-13T) and "RB" (S.A.E. "B" 4-Bolt Flange w/ "B" Shaft 7/8"-13T) as a standard rotatable or as a wet spline rotatable option.

To Order the "RK" as a wet spline option insert into the P.T.O. model code the letter "W" (Wet Spline) or "V" (Wet Spline w/ Valve Body Rotated 120°) as the "Lube" option and the letters "RK" for the output option.

To order the "RK" as "Standard" (non-wet spline), the "Lube" option would be "P" or "R" and the letters "RK" for the output option.



OVER

- Wet Spline flange is shipped loose with bolts, gaskets, fitting and hose.
- If ordering a standard “RK” the Flange will be shipped loose with bolts. A gasket is not required between the flange and the P.T.O. bearing cap.
- Standard flange part number:
 - 21-P-759
- Wet Spline flange part number:
 - 21-P-722

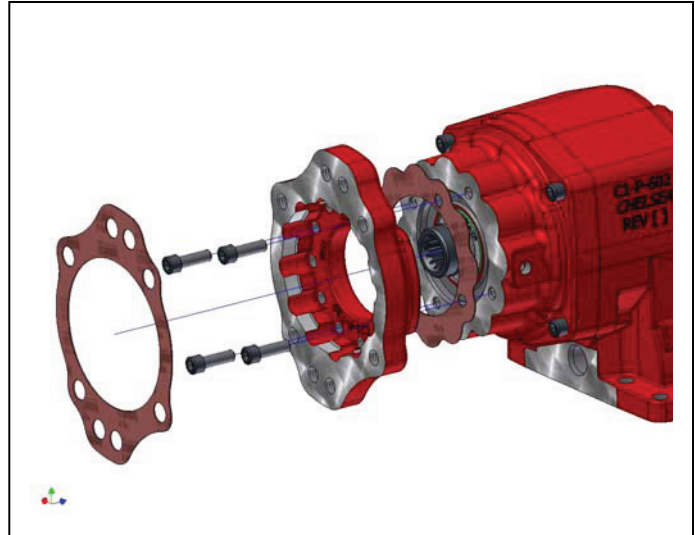

- Conversion Kit: “RK” Standard to “RK” Wet Spline
 - 329160-67X

- Refer to Chelsea Owner's Manual HY25-1380-M1/US for torque specifications when installing the rotatable flange to the P.T.O. bearing cap.

- List Price:
 - “RK” Standard: \$197.38
 - “RK” Wet Spline: \$317.95

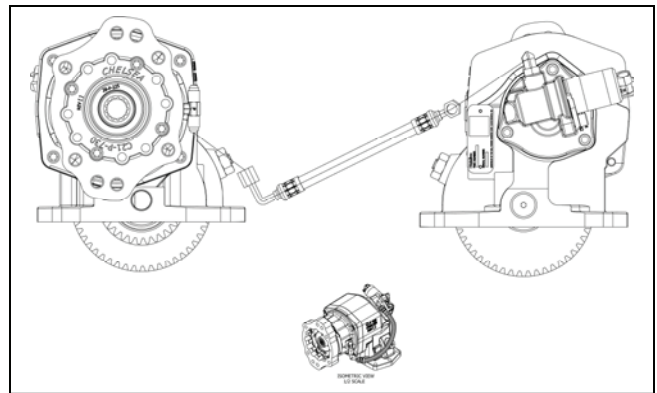

- Orders for the new flange options may be placed on or after October 15, 2010.

If you have questions about this bulletin or other technical questions, contact us at:

US: Chelsea Customer/Technical Services at **1-888-PH4-TRUK** (1-888-744-8785)
 Canada: Parker Hannifin Canada at 905-693-3020

Walt Harris
 Product Sales Manager
 Chelsea Products