

New 252 Series

For Dodge/Aisin and Allison 1000, 2000/2400 Series



Features & Benefits



- Controlled Compression Interface Gasket – Eliminates the setting of Gear Backlash
- Lightweight Housing Design – Allows for Maximum Heat Dissipation
- Excellent Gear Contact Ratio – Quiet Operation
- Weather Tight Electrical Connectors – Secure Under Vehicle Connections
- Integrated Cartridge Valve – Reduced Installation Time
- Compact Size – Can Fit Through Dodge Floor Access Panel for Transmission Installation Saving Time
- Torque up to 120 Lbs.ft – Able to Power Your Application Requirements
- Two Speed Ratios – Coverage for Varying Applications
- Replaces the 250 Series for All Applications

252 Series

Design Improvements

250 Series

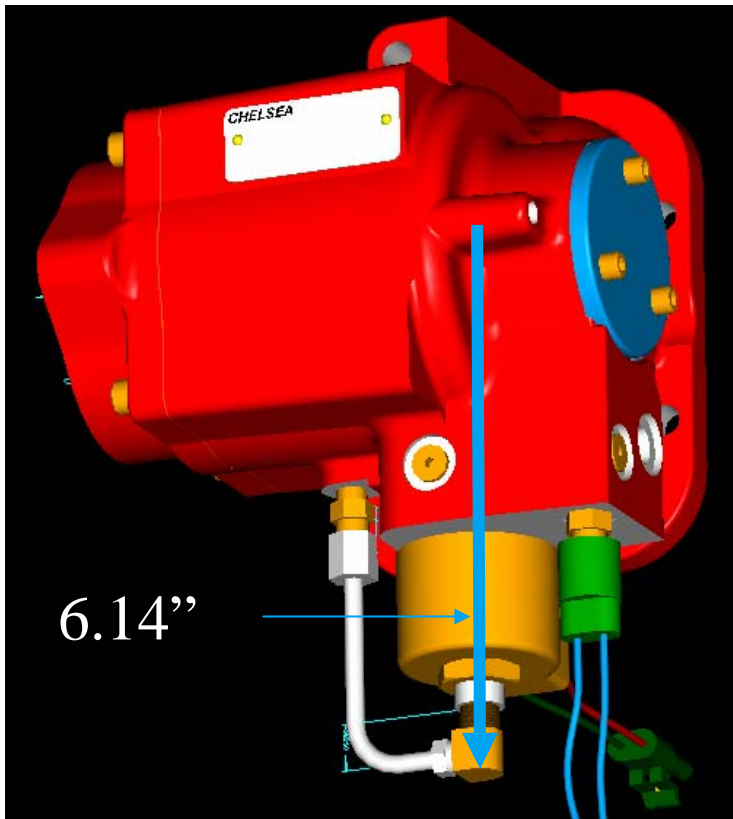

252 Series

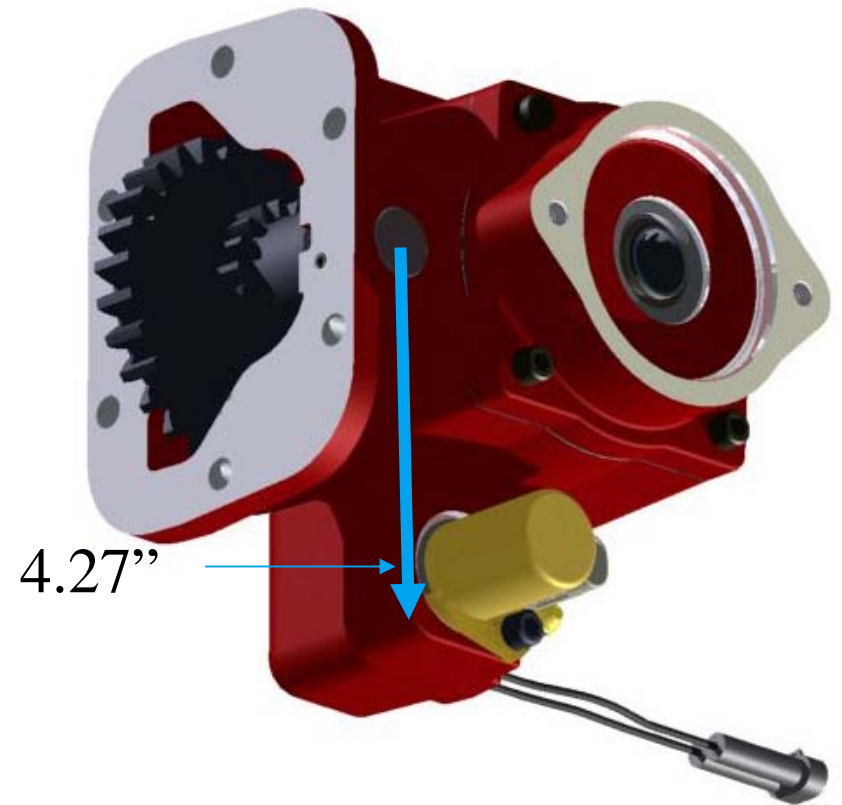



252 Series for Dodge w/ Aisin Automatic



- Torque : 85 Lbs.ft — Limited by transmission line pressure
- Output Speed: “D” Ratio - 99% of engine
- Outputs: XE (5/8” 9T)
XB (1” Round w/ Key)
AD (3/4” 11T)
- Model Number: 252DDKUX-B5****
252DMKUX-B5****

252 Series Allison

1000, 2000/2400 Series

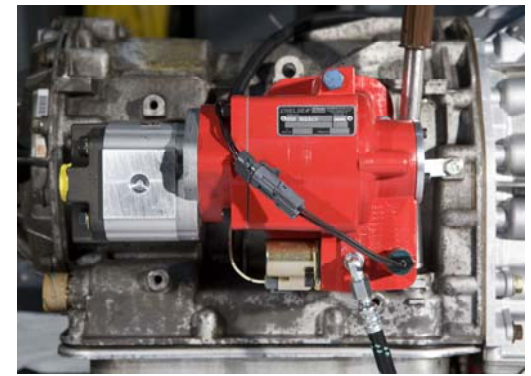

- Torque : 50 - 120 Lbs.ft
- Output Speed: 178%(M) & 122%(D) of engine
- Outputs: XE (5/8" 9T)
XB (1" Round w/ Key)
AD (3/4" 11T)
- Pressure Lube: "P" Option Required for Left Side Installations on 1000, 2000/2400 Series
- Model Number: 252GDHVX-B5****
252GMHVX-B5****



Pumps – 252 Series

Pumps offered in the 1*** Order Code are SAE “B” 2 Bolt w/ 5/8” 9T Shaft. All P** Order Code Pumps are SAE “B” 2 Bolt w/ 3/4” 11T Shaft

Order Code	Chelsea Pump model	Displacement in ³ /rev	Displacement Gal/rev	Cont. Pressure psi	Max Speed rpm	Shaft Size
1116	CGP-P11C016-1AC	0.37	0.0016	3988	4000	5/8" - 9T
1121	CGP-P11C021-1AC	0.49	0.0021	3988	4000	5/8" - 9T
1126	CGP-P11C026-1AC	0.61	0.0026	3988	3600	5/8" - 9T
1129	CGP-P11C029-1AC	0.67	0.0029	3988	3600	5/8" - 9T
1137	CGP-P11C037-1AC	0.85	0.0037	3988	3300	5/8" - 9T
1449	CGP-P31C054-1AE	1.24	0.0054	3500	3000	5/8" - 9T
1462	CGP-P31C061-1AE	1.40	0.0061	3500	3000	5/8" - 9T
P37	CGP-P11C037-5AC	0.85	0.0037	3988	3300	3/4" - 11T
P42	CGP-P11C042-5AC	0.98	0.0042	3988	3000	3/4" - 11T
P71	CGP-P11C071-5AC	1.65	0.0071	2900	2400	3/4" - 11T
P82	CGP-P11C082-5AC	1.89	0.0082	2465	2300	3/4" - 11T

NOTE: P82 Pump not available for the GM 3600 Cab Chassis

252 vs. 270 Installed



252 weight = 20 lbs.



270 weight = 49 lbs.