

Reservoir Capabilities

Reservoir System Solutions for the
Toughest Hydraulic Applications



Customer Value Proposition:

- Lightweight, flexible space saving designs
- Reduced leak potential with SAE connections on multi-port systems
- Environmentally friendly, top loading filter elements reduce maintenance cycle times
- Long life microglass media keeps systems clean with improved service intervals



Contact Information:

Parker Hannifin Corporation
Hydraulic Filter Division
16810 Fulton County Road #2
Metamora, OH 43540 USA

phone 419 644 4311
fax 419 644 6205
hydraulicfilter@parker.com

www.parker.com/hydraulicfilter

Customer Benefits:

- Engineered reservoir systems with innovation in filter performance, system cleanliness, heat rejection, back pressure reduction, mounting and system service.
- Designed to meet specific customer requirements including unique geometries, fluid volumes and system accessories.



ENGINEERING YOUR SUCCESS.

Application matched filter reservoir designs



Hydraulic reservoirs with integrated filtration solutions

Cylindrical design reduces space. Cold rolled steel for rugged reliability and improved heat dissipation. Top service patented filter reduces service time and minimizes fluid loss. Minimal fluid contact for improved safety. Visual sight gauges provide oil levels at a glance. Microglass media offers cleaner fluid and increased element service life. Filter breather reduces dirt ingress and eliminates oil mist. Multiple port configurations for power steering and case drain.



- Applications include:
- Fan drive systems
 - Turf equipment
 - Mini-construction



Extruded aluminum and cross flow filter reservoir design (.5-2 gallons)

Compact, lightweight extruded aluminum fin designs offer improved heat rejection and installation alternatives. Integrated return filter delivers specified fluid cleanliness and ease of maintenance.

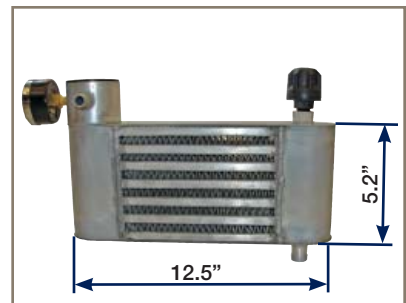
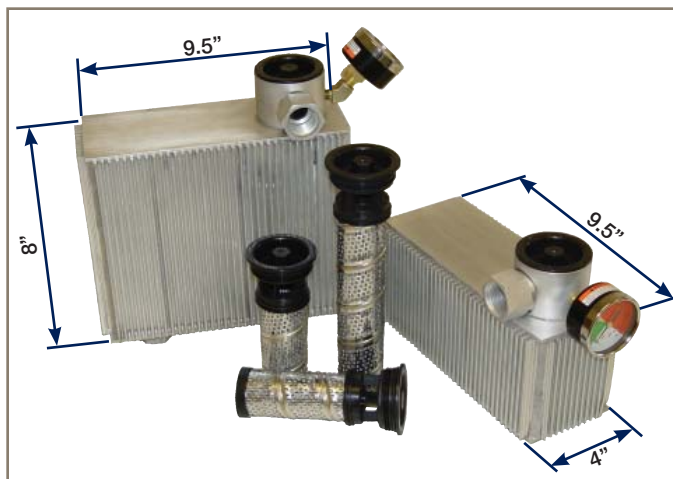

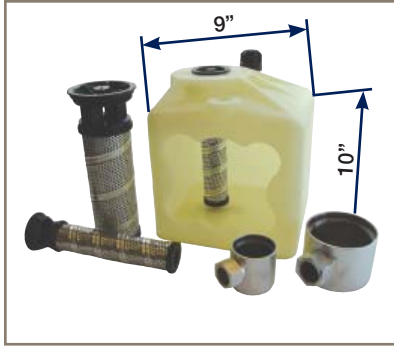

Rotational molded filter reservoir designs (2-4 gallons)

Composite, lightweight designs with integral top mounted filter and breather. Flexible geometry allows for custom space saving installation. Patented filter with microglass media delivers the specified fluid cleanliness level while providing for extended element service life.

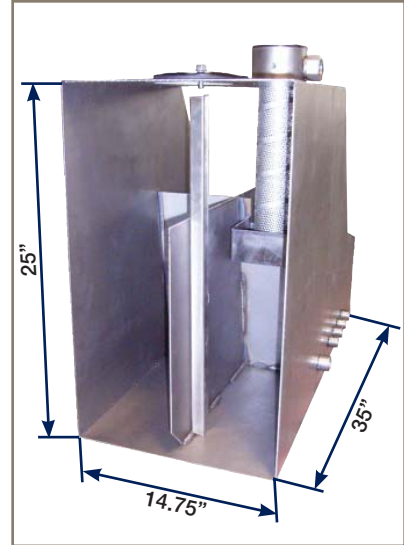

Custom fabricated high volume filter reservoir designs (10-150 gallons)

Reservoir systems that are engineered to meet demanding application requirements. Available features include baffles for air separation, filter breather assemblies to control atmospheric contaminant ingress, fluid level and temperature gauges and numerous porting options.



Applications include:

- **Aerial lifts**
- **Fork lifts**
- **Transit vehicles**
- **Heavy construction**
- **Mini-construction**

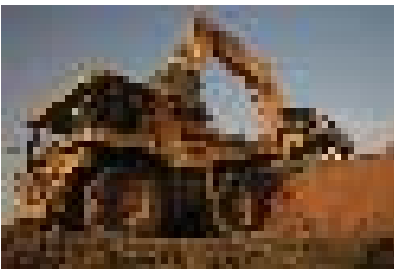

Hydraulic fan drive reservoir filter system (5-10 gallons)

Custom fabricated assemblies with special mounting provisions and unique geometries that allow for easy installation and plumbing.

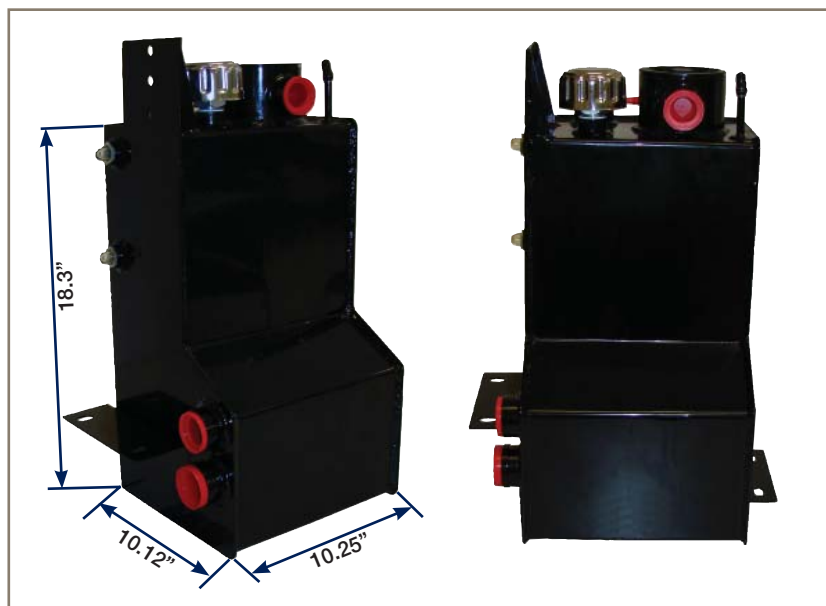

Reservoir Design Criteria Worksheet

Reservoir Quick Check List

1. Is annual volume a minimum of 120 pieces?
2. Do you have geometry and fluid volume requirements?
3. Do you know material of construction?
4. Do you know filter and accessory requirements?
5. What is fluid and operating temperature?
6. What are all porting requirements?



Value Delivered:

- Naturally clean reservoir ⇒ No weld slag or metallic contamination
- 100% space efficiency ⇒ Reservoir designed to utilize every inch of available space
- Parker filtration media ⇒ Performance defined and verified by independent laboratory testing
- Inside-to-outside flow element ⇒ Contamination is removed with serviced element
- Bypass valve in the element ⇒ New with each element replacement
- Simple maintenance ⇒ .625 in. (16 mm) hex on the element cover
- Cost effective ⇒ No additional housing or bowl required

Customer name/location: _____

Type of equipment of machine: _____

Type of fluid/fluid supplier/grade: _____

Preferred reservoir material: Cross-linked polyethylene Steel Aluminum Other _____

Flow & Filter Preferred Element: PT2 to 20 gpm PT4 to 40 gpm KLT to 120 gpm

Est. annual usage (120 min. metallic/500 min. plastic): 1 year: _____ 2nd year: _____

Maximum fluid temperature (160°F max.): _____ Maximum steady state flow rate (gpm): _____

Maximum surge flow rate (gpm): _____

Fluid volume (150 gallons for metal, 20 gallons max for plastic): _____

Color: _____ Texture: Yes or No *Approximate dimensions (inches): _____

Return line port type (Barb or SAE): _____ Location: Top Bottom Side

Size: PT2 (SAE-16 max.) PT4 (SAE-20 max.) KLT (SAE-24 max.)

Suction line port type (Barb or SAE), specify: _____ Location: Top Bottom Side

Breather port size (1/4-3/4 NPT), specify: _____ Location: Top Bottom Side

Fluid level gauge required: Yes or No Location: Top Bottom Side

Customer label required: Yes or No Location: Top Bottom Side

Element: 02Q 05Q 10Q 20Q Bypass cracking pressure: 25 psi or 50 psi

Internal baffle required: Yes or No Mounting provisions: _____

Prototype required: Yes or No Prototype delivery date: _____

Target cost: \$ _____ Production quantity release date: _____

System concerns: _____ Cooling: _____ Air release: _____

**Please provide all current dimensional drawings.*

